

G3 V3



M3 Assembly, Operating & Maintenance Instructions



## **T1-SB**

Toyota Tundra 2007-Current with 78" bed

---

**Installation Support**

[www.peragon.com/support](http://www.peragon.com/support)

877-473-7246 ext 2



## Important Owner Information

- Read this manual before attempting to assemble, install, operate or maintain your Peragon cover. Failure to follow instructions may result in personal injury, death and/or property damage.
- Your Peragon cover is for inanimate cargo only. Never transport any person or animal in the pickup bed. No one should sit, stand or lie on or under the cover. Never haul anything on the cover. Do not set any object that could damage the finish or weighing more than 50 pounds on the cover.
- Secure cargo to prevent shifting or it may damage your Peragon cover and/or the cargo. Never use any part of your Peragon cover to secure cargo.
- Your Peragon cover is not waterproof. Items that could be damaged by water should not be stored in the pickup bed during inclement weather or through a car wash. Peragon is not responsible for water damage to cargo.
- Your Peragon cover is a deterrent to theft, it will not prevent it.
- If the cover does not operate smoothly, NEVER force it. During the one to two week break-in period, it is normal for the operation of the cover to be a little stiff. Use spray silicone lubricant on the hinge points for smoother, quieter operation. Wipe off excess. If the operation is excessively stiff or you'd like more maintenance information, contact us at [sales@peragon.com](mailto:sales@peragon.com)
- Every month inspect and tighten all bolts on the cover and mounting brackets.
- Clean your cover with a mild soap and water solution. Turtle Wax with Carnauba is excellent for water spots. Use care to avoid getting wax on the seals. Finish damage caused by chemicals or other environmental conditions is not covered by warranty.
- If your cover is frozen, gently tap around the edges to break up the ice and allow the cover to open.
- If your cover is scratched, use touch-up paint to prevent flaking around the scratch. For Classic Black -Dupli-Color Universal Black All-in-1. For Arctic White - Dupli-Color Universal White All-in-1. For painted to match - check with your local dealer or auto parts store.
- NOTE: These instructions describe safe operating procedures. If you install this cover for another person, it is important that you give them this manual and they read these instructions before using the cover

## Before You Begin

### Plan Your Installation

Review the entire manual before starting. Follow all steps exactly. Do not guess your way through the install. The cover will not work properly if you do. This would be a good time to review our installation videos at <https://www.peragon.com/support/installation-videos/>. Each page of the installation manual will list the corresponding video, if applicable. The hardware pouches follow the assembly steps. Start at the beginning of the manual and with the first pouch. Work forward, page-by-page.

Feel free to call our tech line to discuss the installation before you begin. Depending on the number of questions you have, it will take 20 to 40 minutes to go through the manual with you. Visit <http://peragon.com/support> for current phone support hours.

### Inspect Your Shipment

Your cover is shipped in two boxes. You may have received only one box. The second box can follow a day or two behind.

Inspect for damage. Contact Peragon immediately if you find damage. We will file a claim with the carrier and ship a replacement when available at no cost to you.

**Important!! - We recommend you save the boxes and foam packing blocks at least until you are sure you will not be returning the cover. It is best to save the packaging long term, just in case you ever need to ship your cover back for warranty work. Replacement packing material is expensive and we don't accept returns unless original packaging is used.**



### Tools Required

Tape Measure	Electric drill with 1/4" bit (if drilling is required)
#1 Phillips screwdriver	(2) 7/16" wrenches
(1) 1/2" wrenches	3/8" wrench
1/8" Allen wrench	

### Use of Power Tools

Power tools will over tighten the fasteners and cause damage. Do not use power tools.

### Bed Liners (Factory Installed or Aftermarket)

Spray-in liners and the Bed Rug are fully compatible. Over-the-rail plastic liners that wrap over the sides of the truck bed may not be compatible or may require extensive modification. Most under-the-rail bed liners DO NOT require modification. Exceptions to this include liners that do not fit snugly against the truck bed. In rare occasions, if a liner does not fit snugly and a lot of space exists between the liner and the truck bed, some modification of the liner can be required in front of the wheel wells. Liners in compact trucks may require modification in front of the wheel wells to allow adequate clearance for parts of the Peragon system.

## Bed Rail Protectors (Factory Installed or Aftermarket)

Plastic bed rail protectors are completely compatible with the Peragon cover. Do not remove them and in most cases you will not need to cut them. The Peragon rail will sit on top of your bed rail protector. If you are instructed to drill in order to mount the 'L' brackets on the inside of the bed lip, you will drill through the bed rail protector and mount our bracket on it. If you are directed to install the brackets adjacent to the stake pockets, you may have to cut out the openings on top to reveal the stake holes. If your bed rail cover is removable (double faced tape, screws or clips) **AND** you are required to access the stake pocket holes for bracket mounting, you may want to remove it temporarily to fasten our brackets and then it can be reinstalled. Be cautious and don't remove or modify the bed rail protector unless you are certain you need to. If you find that you will need to cut open the stake holes and you would rather not, PLEASE call us, we can help you determine if there's a way around it. 877-473-7246 x2.

If you decide to cut the stake pocket holes open and you wish to cover these holes back up, you can glue the cut out back in or you can purchase caps. Do a Google search for "truck bed stake pocket covers" and you will find several sources.



### **Very Important**

When you get to the step on rail alignment, please ensure that the rails are level with respect to the top of the truck's tailgate. Bending the bracket leg is usually the most effective way of accomplishing this. If the rails are not level, the cover may be difficult to operate or it may leak more. The photo to the right shows a level rail.

Take the time to watch the videos at <https://www.peragon.com/support/installation-videos/>

POR-15, <http://www.por15.com> is an effective rust inhibitor for drilled holes.

**ATTENTION!!** Many installations require drilling holes to mount brackets. It is not possible for us to anticipate every situation. If drilling is required, this manual will explain where to drill the holes. You are responsible for adapting our instructions to fit your particular situation. Be sure that you'll be able to install a washer and nut onto the bracket bolt **BEFORE** you actually drill the hole. Please call us if you have a question 877-473-7246.

**If you ordered the stainless steel fastener upgrade** - To ease the assembly of the stainless steel bolts and prevent galling, we recommend applying a lubricant to the threads. A dry product such as graphite or talc (talcum powder) is preferred.



# Theory Of Operation



Before beginning, take some time to familiarize yourself with how the cover operates. This will make the installation easier. Reference this diagram and the description on the next page

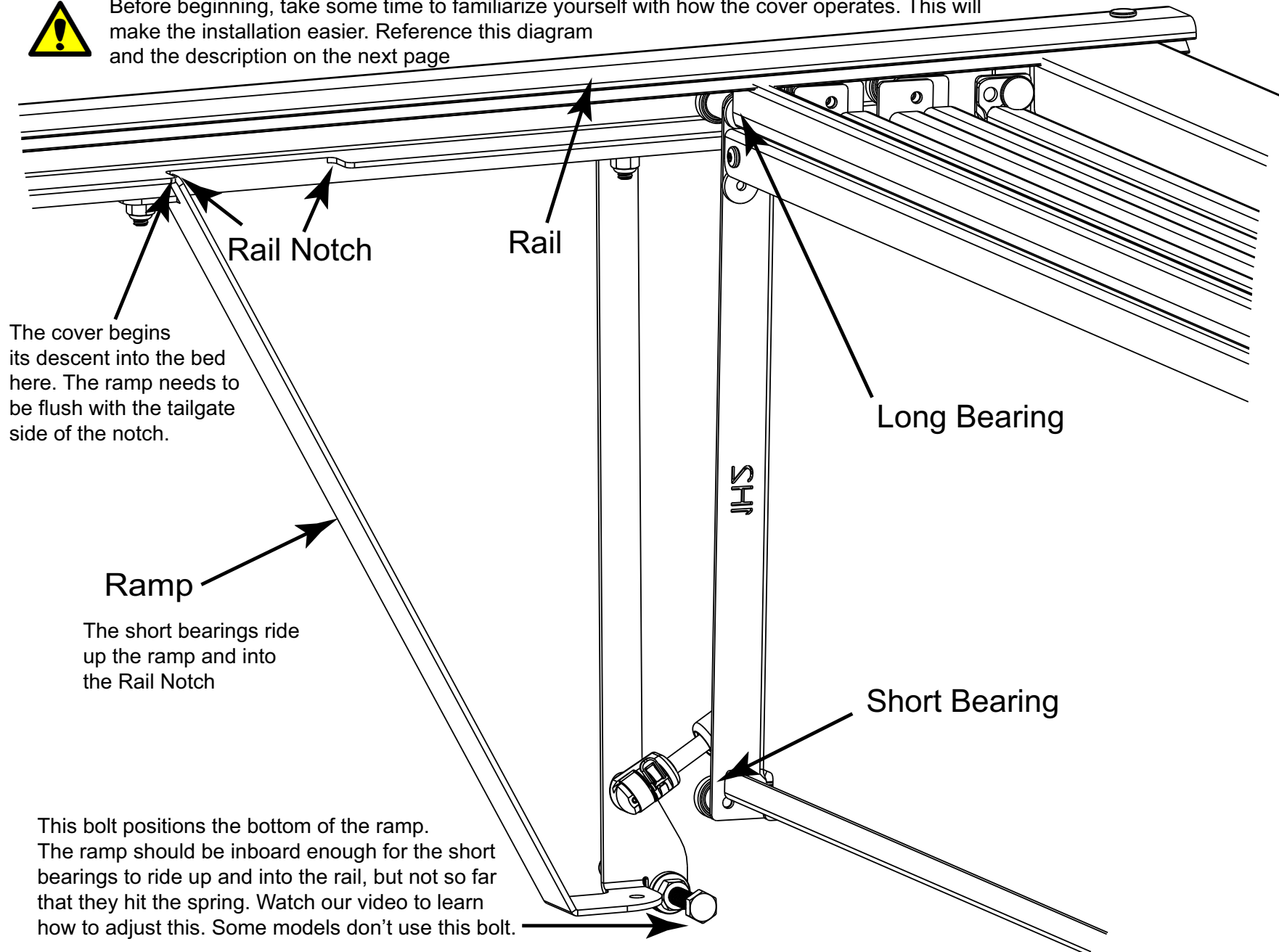

## Retraction

Use the interactive demo found on our web site as you read this section. Visit <http://peragon.com/features> - the demo is found in the "Retractable" section

The first panel behind the cab is held in the up position by two gas springs. To begin the retraction process, you push the first panel down into the bed until you have compressed the springs and completely pushed the panel down. At this point, the remaining panels will either retract on their own or you may have to assist them a little.

1. The panels have roller bearings on the side that are engaged into the rails.
2. Every other hinge has a bearing that is shorter.
3. This shorter bearing descends into the bed through a notch on the underside of the rail. As it does this, it pulls the other panels forward.
4. The next hinge has a long bearing that stays in the rail.
5. This alternates until the cover is fully retracted.
6. The long bearings stay in the rail and serve as the "hangers".

## Extension

The strap is pulled to extend the cover over the bed. As the cover is extended, the short bearings ride up on the ramp, into the rail notch, into the rail and move to the rear. When the cover is almost closed, the springs finish the process by pushing the first two panels up into the closed position. If the panels on your cover are not coming completely up or if the lock rods are not engaging into the rail, give the seals a few days to break-in. Eventually, the seals will conform to their new shape and the cover will fully close and the lock will work as it should. However, if your rails are not aligned correctly, your cover will not work properly. No amount of time will make up for an incorrectly installed rail system. Take your time and work carefully when you install and adjust the rail system. Watch our videos at <https://www.peragon.com/support/installation-videos/>

## Incremental Positions

To keep the cover in a partially open position, you need to prevent the short bearings from descending the ramps by moving them past the notch in the rail. Continue sliding the cover forward until it stops. Wrap the nylon strap over the top of the panel group and tie it off. This procedure can be done with each of the two short bearings hinges, resulting in  $\frac{1}{3}$ ,  $\frac{2}{3}$  or fully open cover. If you have a cover with 8 panels, then the cover has 3 sets of short bearings and you can have the cover in the  $\frac{1}{4}$ ,  $\frac{1}{2}$ , and  $\frac{3}{4}$  open positions.

# Rail Frame Assembly

SEE VIDEO #2 FOR THIS STEP



Assemble upside down on the gray foam blocks that are in the cover box

Passenger Rail

Driver Rail



## Common Error!!

Some folks reverse the rails, putting the driver on the passenger side. This will make the rail system appear too narrow. They are marked underneath with a 'D' or 'P'. Double check this!!

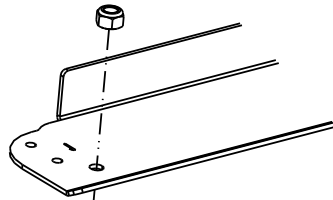

Driver Rail

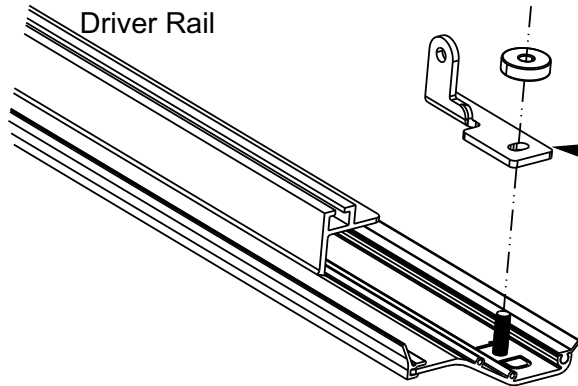

These brackets MUST sit firmly and squarely in the rail. Be sure of this BEFORE tightening the nuts. Tighten nuts until snug.

**DO NOT OVERTIGHTEN!**

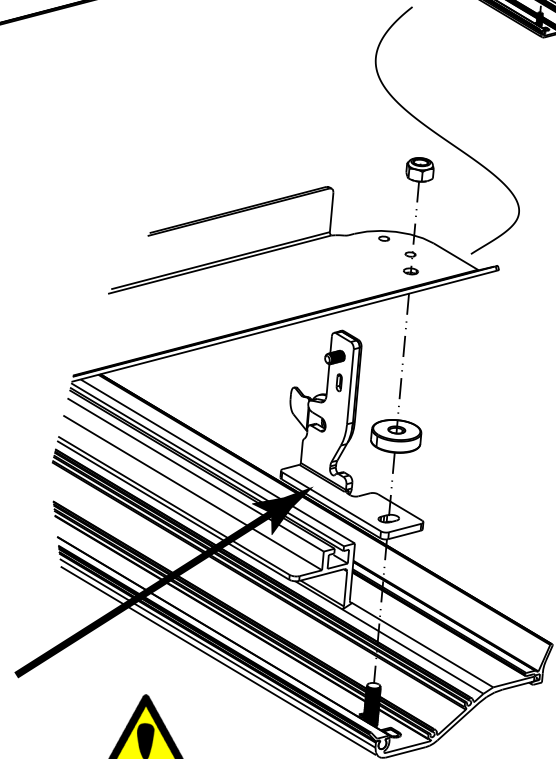

Passenger Rail

# Assembling the Ramps

SEE VIDEO #3 FOR THIS STEP

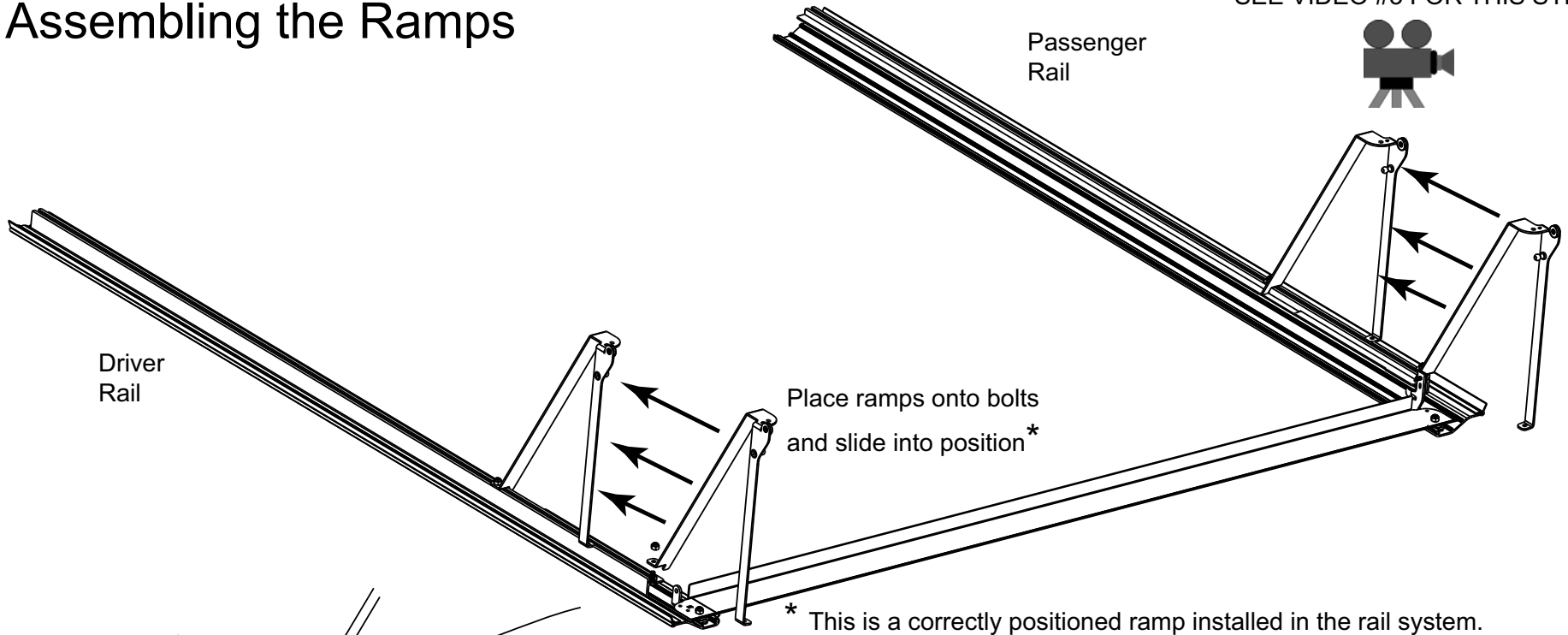

\* This is a correctly positioned ramp installed in the rail system. Tighten nuts until snug. Do not overtighten!!

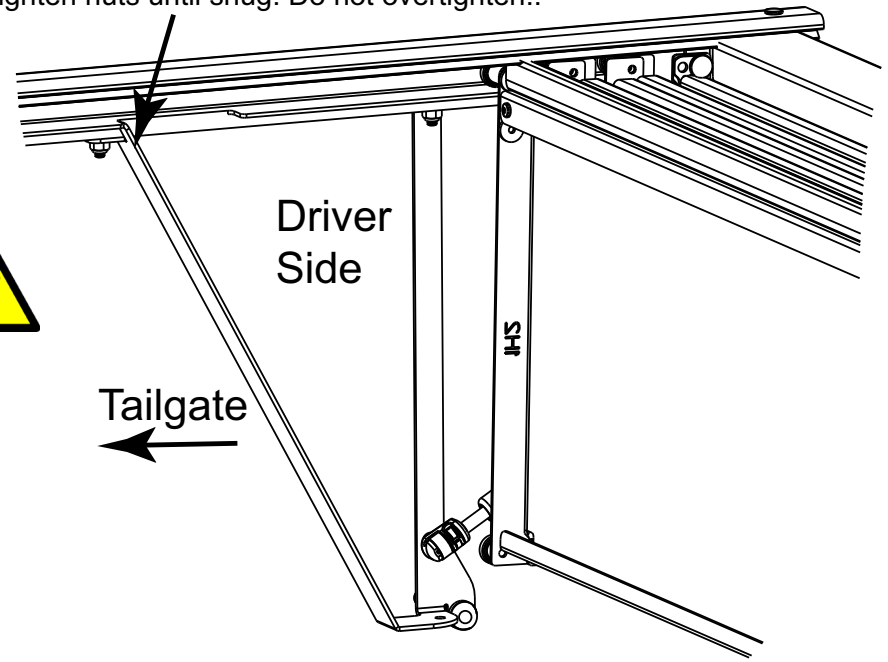
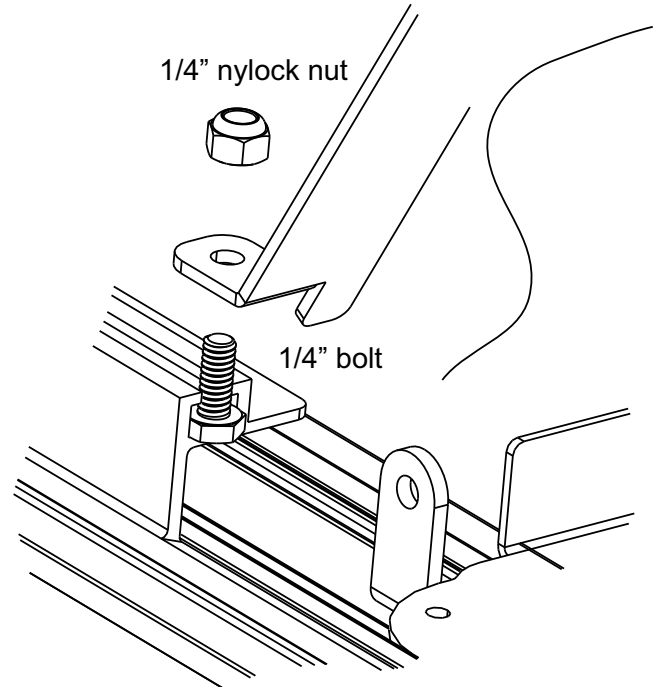



# Attaching the Rail Crosspiece Seal

SEE VIDEO #4 FOR THIS STEP



- A. Clean with alcohol and allow to dry before attaching seal.
- B. Watch the video and notch the seal as described and avoid cutting too short!!
- C. Starting on the outside edge, press seal **VERY FIRMLY** along its entire surface onto rail cross piece and underside of rails as shown
- D. Trim to fit.

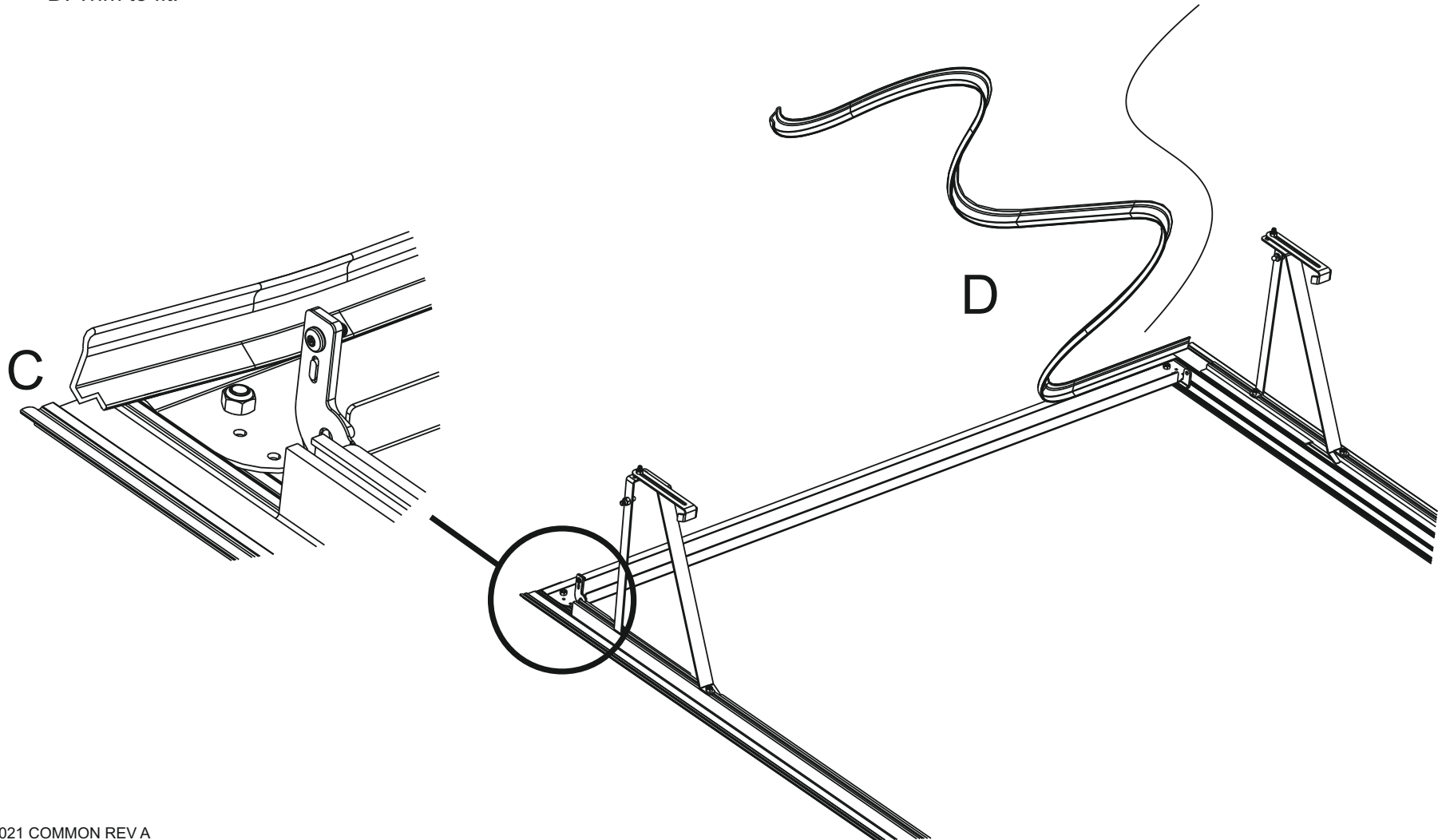
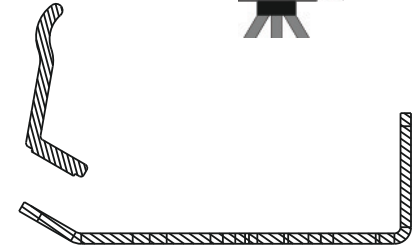

# End Cap Installation

SEE VIDEO #5 FOR THIS STEP



Cut tabs to separate end caps →

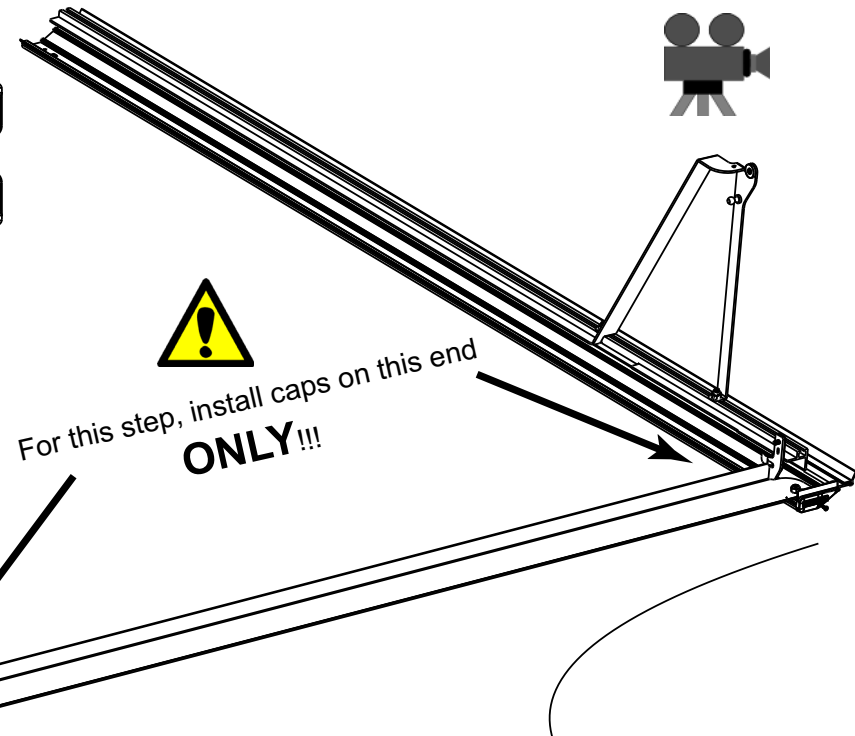
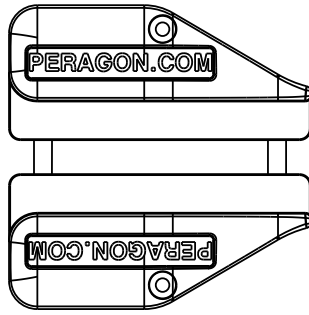

A dab of super glue on the edges of the end cap will help hold end caps in place. Watch to make sure you don't get glue on the rail surface!

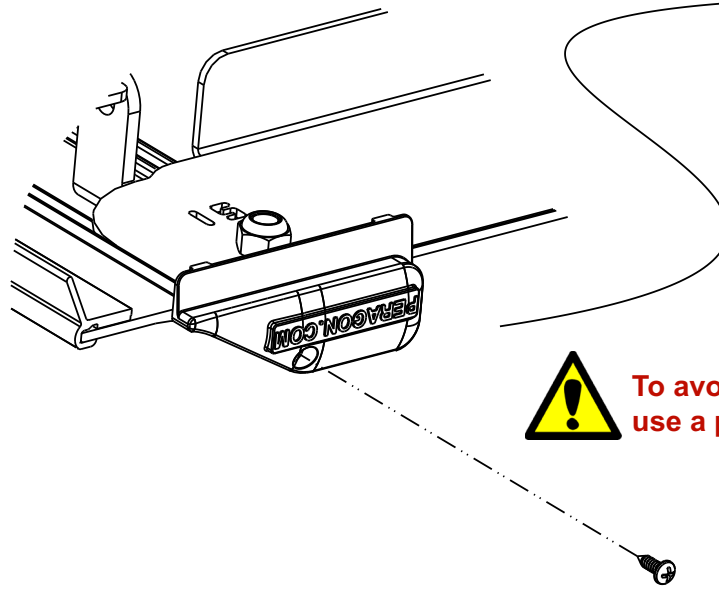

To avoid damage, do not use a power screwdriver

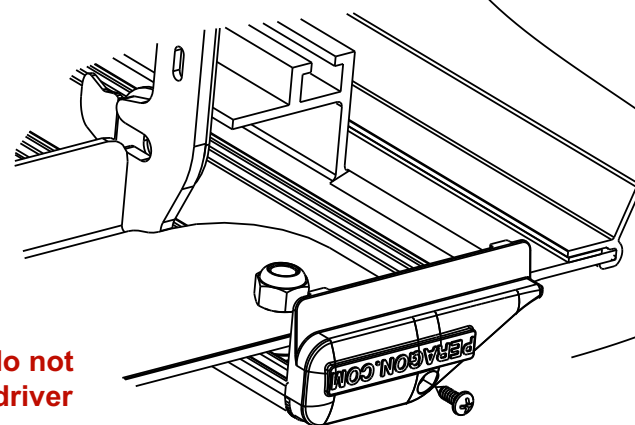

# Apply Tape to Side Rail Seal

SEE VIDEO #6 FOR THIS STEP

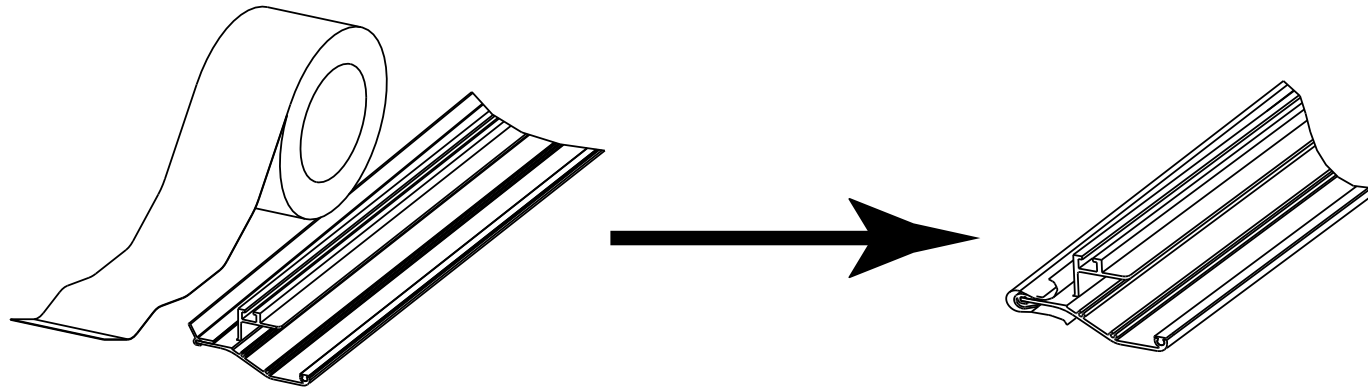

DETAIL A

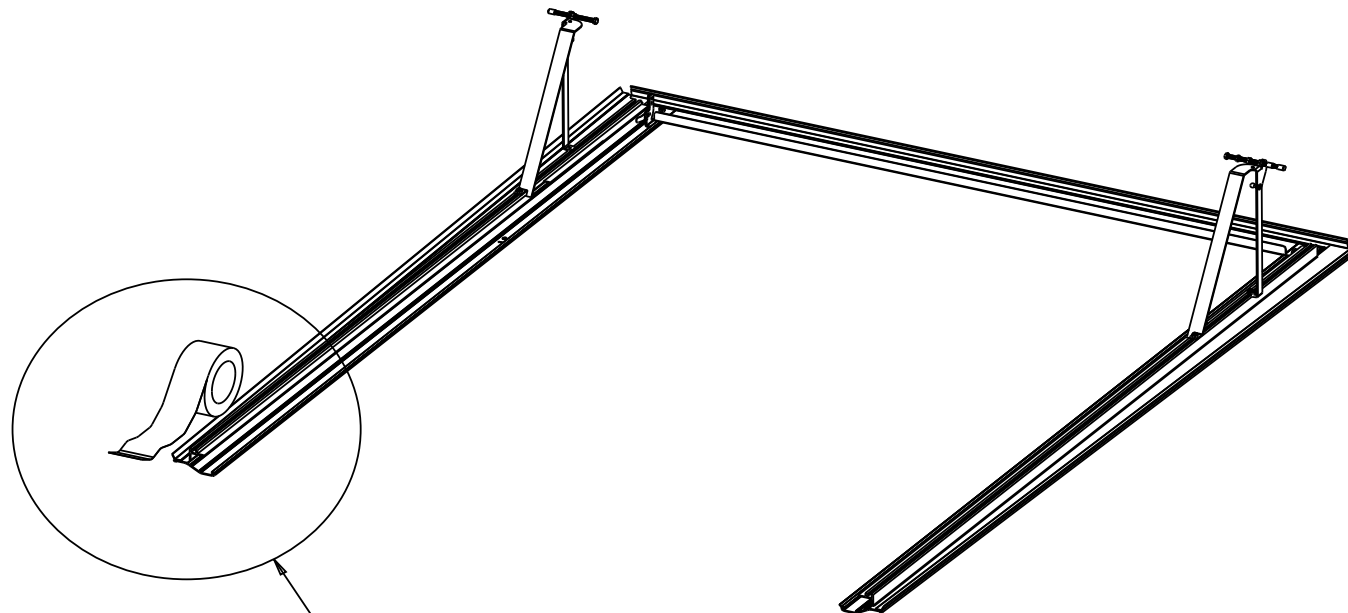

SEE DETAIL A

# Mounting Bracket Locations

SEE VIDEO #7 FOR THIS STEP



To do:

- 1) Mark hole locations per dimensions below
- 2) Drill 1/4" hole at the 4 locations indicated



**Caution:** Before drilling, be sure you'll be able to install the washer and nut on the bolt that will go in that hole. Be sure there will be sufficient metal between the hole and the bottom part of the bed rail lip. Call if you have questions. 877-473-7246.

Inside Edge,  
Front Rail

Drilling is required for the Tundra.  
You CANNOT use the pre-existing  
holes in your bed unless you develop  
your own mounting method.

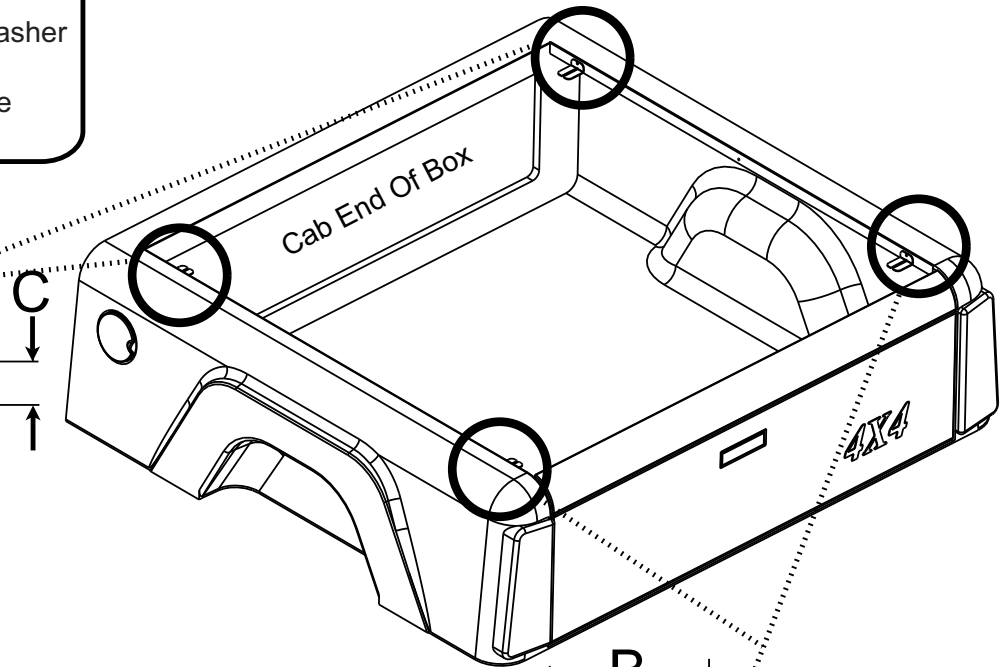
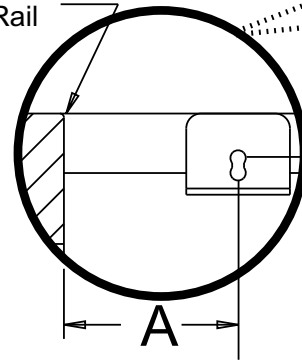

Dimensions:

**Ensure hole position doesn't restrict access for installing the nut and washer on the bolt.**

A: 4-3/4" from front, inside edge of bed rail to center of mounting hole. If something will obstruct the installation of the washer and nut, you may move the hole a minimum amount, left or right.

B: 7-1/2" from inside edge of tailgate to center of mounting hole. If something will obstruct the installation of the washer and nut, you may move the hole a minimum amount, left or right. Exact location is not critical, wherever you can place the bolt and install the nut on the back side.

C: Using the bracket as a template, place bracket against the rail lip with the top edge flush with the top of the truck rail, or rail protector if you have one. Mark the location of the top hole, set bracket aside and drill on the mark.

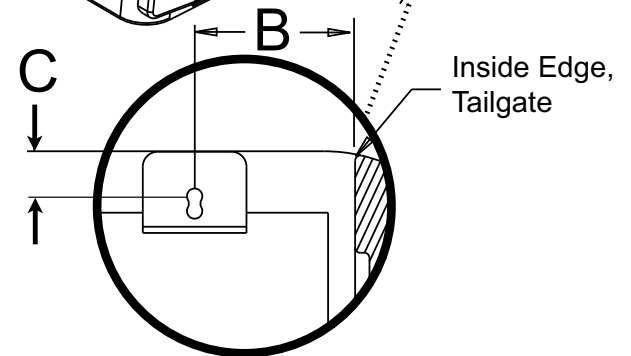

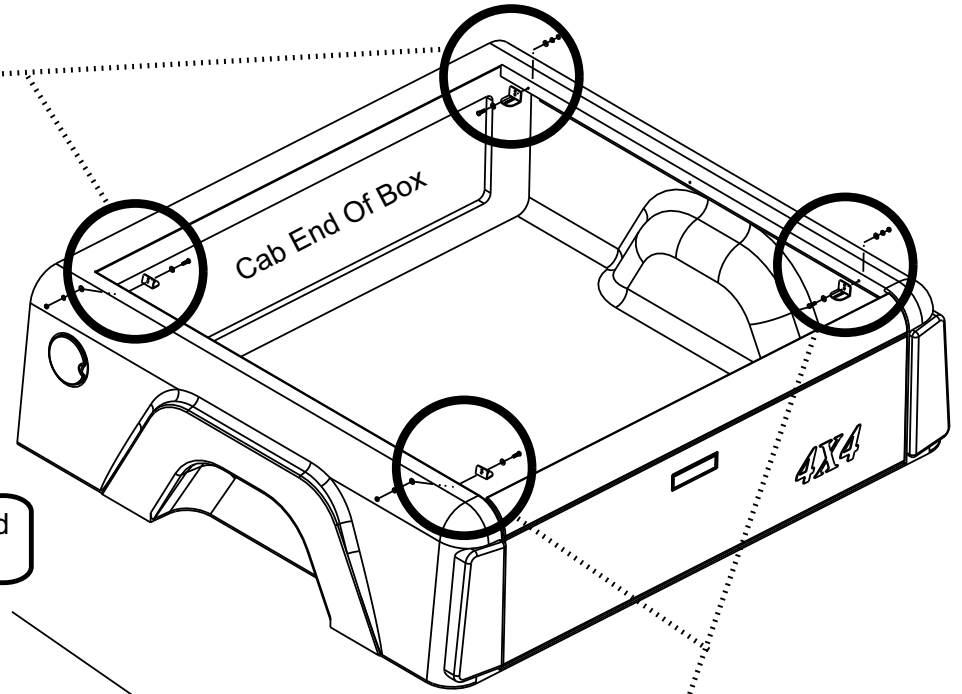
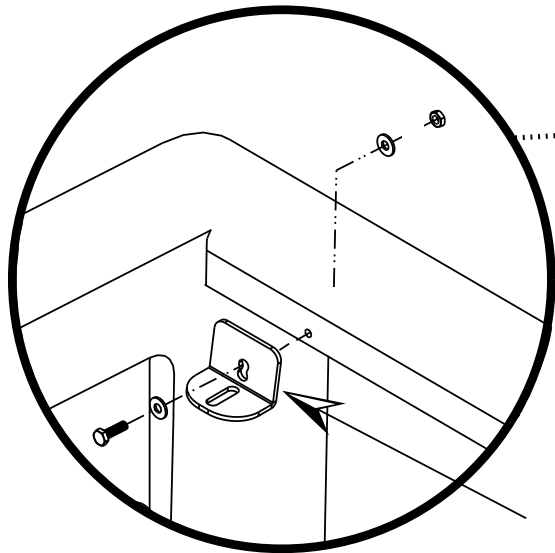
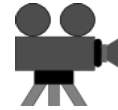

# Mounting Bracket Installation

SEE VIDEO #7 FOR THIS STEP

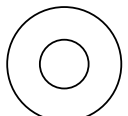

Install brackets at front and rear as shown.

-  1/4" Nylock nut
-  1/4" flat washer
-  1/4" bolt

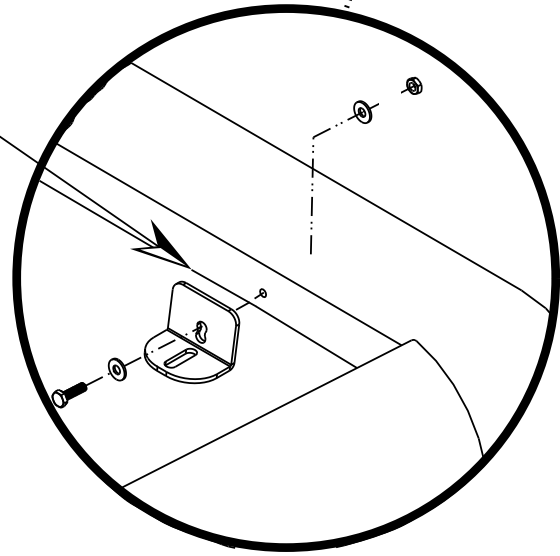

# Installing the Rails

SEE VIDEO #8 FOR THIS STEP

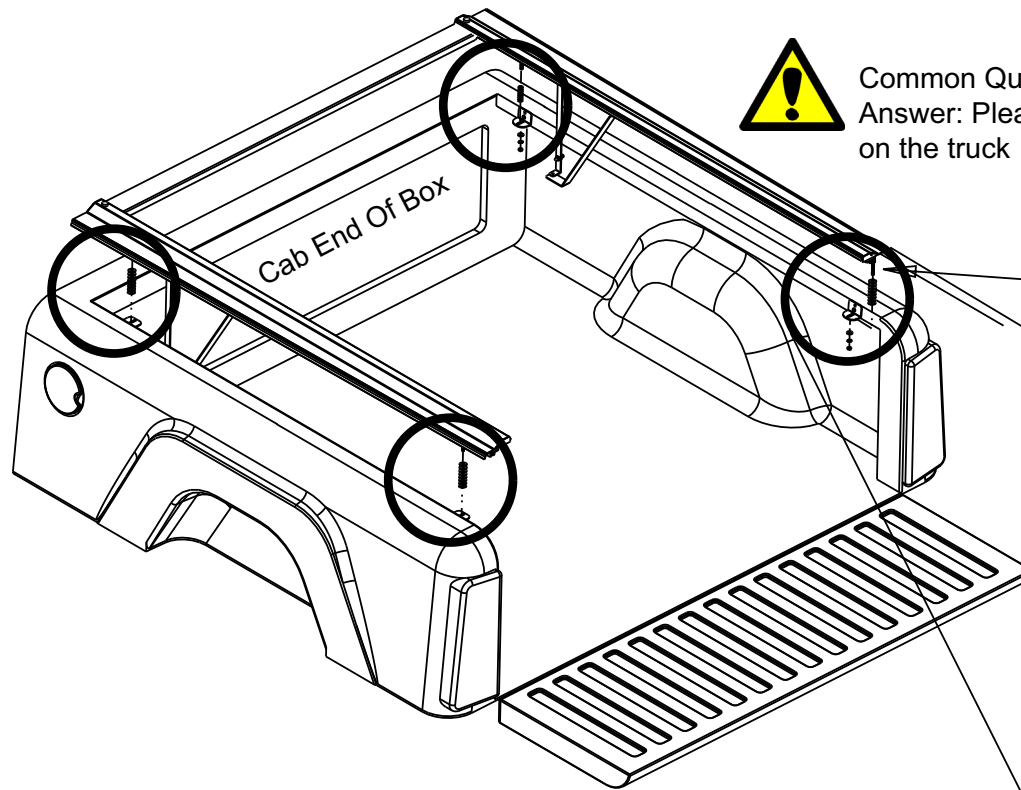

**Common Question: My rails seem too narrow, why?**  
Answer: Please watch video #8 to see how rails sit on the truck

Slide bolts into rail 'T' slots

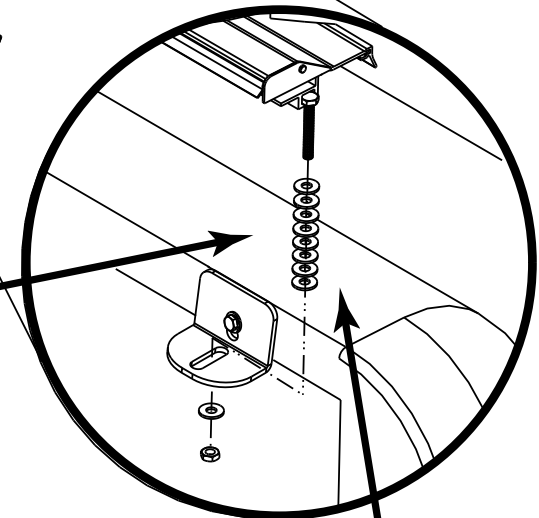

 1/4" Nylock nut

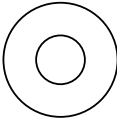
 1/4" flat washer  
(for leveling and spacing see "Rail Alignment" section)

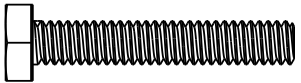
 1/4" bolt



Loosely assemble rails to brackets as shown so that the stack of washers lift the outside edges of the rails about **3/16"** off the top of the truck bed

This is not necessarily the number of washers you will use for adjusting the rail. The correct number will depend on your particular installation. For more information, see video.

# Rail Cross Piece Seal Placement

If the model number of your cover is one of the following (check your order confirmation email), you should consider tucking the rail cross piece seal under the Peragon frame as illustrated below.

C1-SB    D2-QC    D3-SB    F2-SB    NF-QC    NT-QC    T1-QC    T1-SB    TA-SB

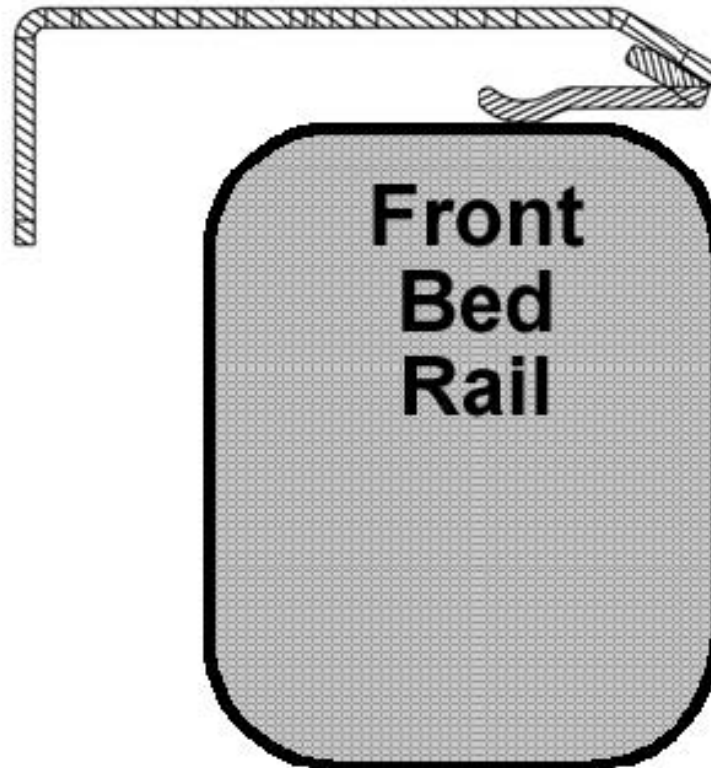

# Proper Rail Fit

It may appear that the Peragon rails are too narrow to fit your truck bed. However, by design the aluminum part of the Peragon rails will NOT extend over onto your truck bed. The outer seal on the Peragon rails will extend over onto your truck bed as shown below. The outer edge of the Peragon rail is designed to “float” and provide the seal while the support for the rail is provided by the mounting brackets.

You will need to make sure the rail system is centered on your truck for proper seal fit on both sides.

By keeping the Peragon rail as far inward as possible, we leave more room for other bed accessories like chrome bed rails.

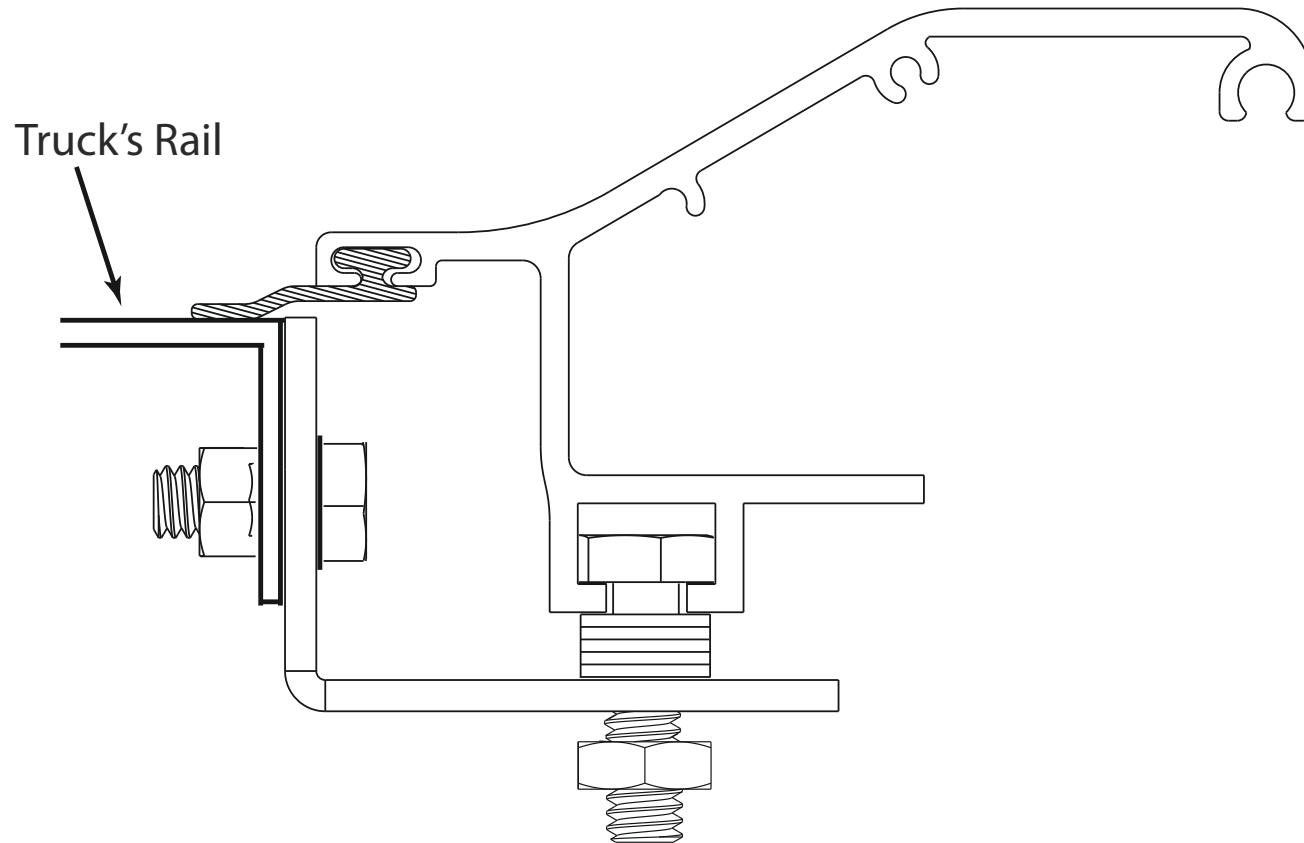



# Installing the Rails, continued

SEE VIDEO #8 FOR THIS STEP

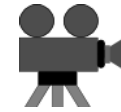

Objectives:

**A.** Make sure the rails are parallel to each other and centered on the box at the cab end.

**B. VERY IMPORTANT:** The indicated section of both rails must be  $\frac{3}{16}$ " from the inside edge of the closed tailgate. Use a  $\frac{3}{16}$ " drill bit for this measurement.

After centering the rails and setting the  $\frac{3}{16}$ " gap at the tailgate, tighten the nylock nuts on the **CAB END** brackets **ONLY**.

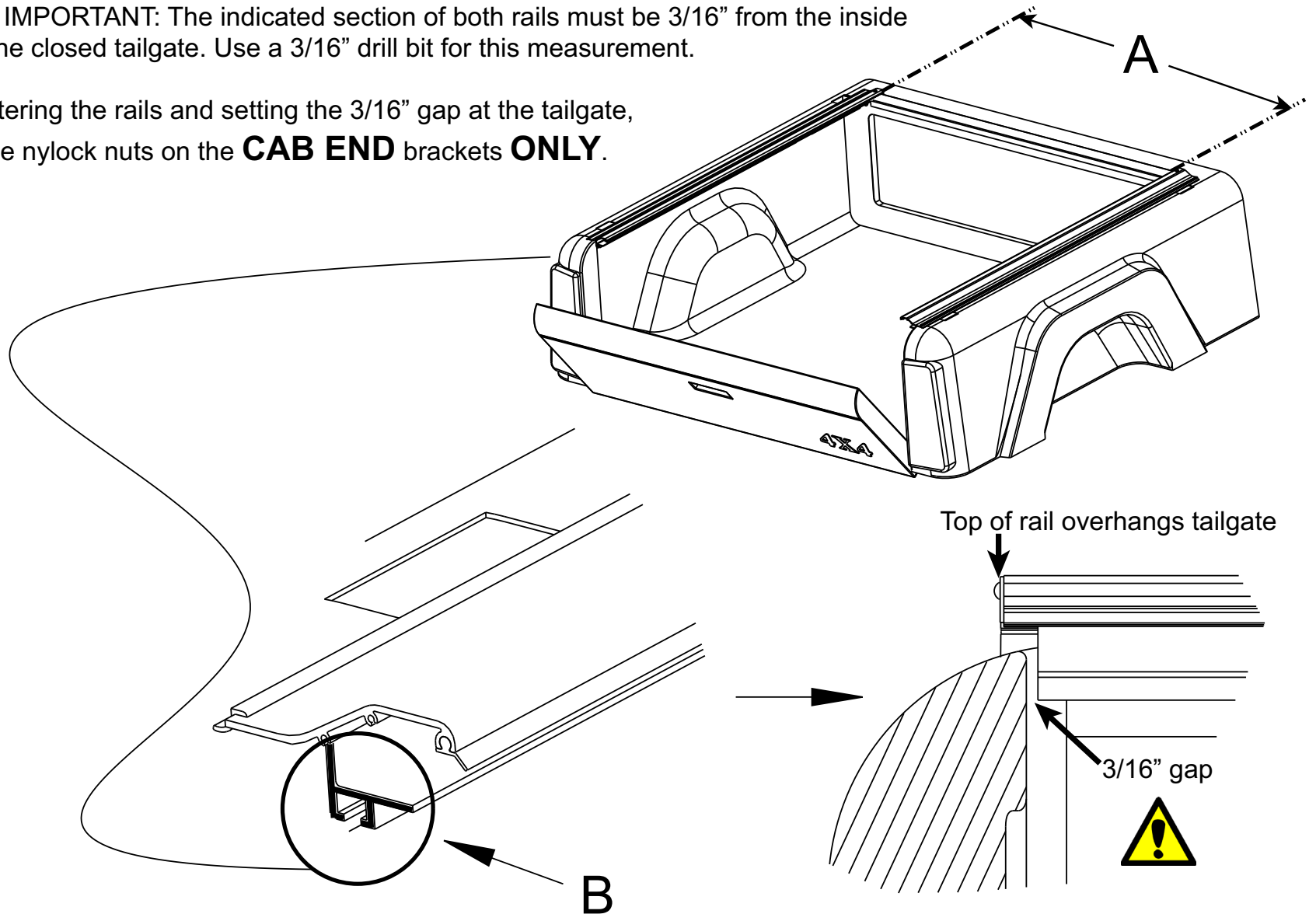

# Preparing the Panel Assembly

SEE VIDEO #9 FOR THIS STEP

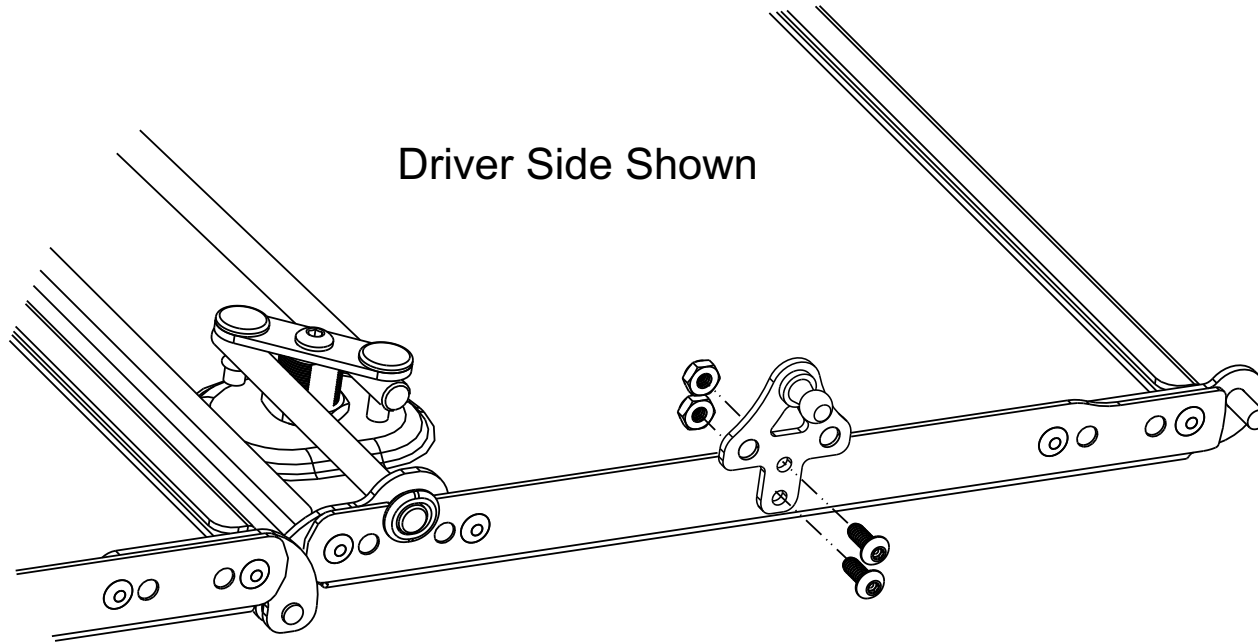
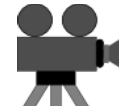

- 1) Position the gas spring bracket as shown
- 2) Attach the screws and nuts
- 3) Repeat on passenger side

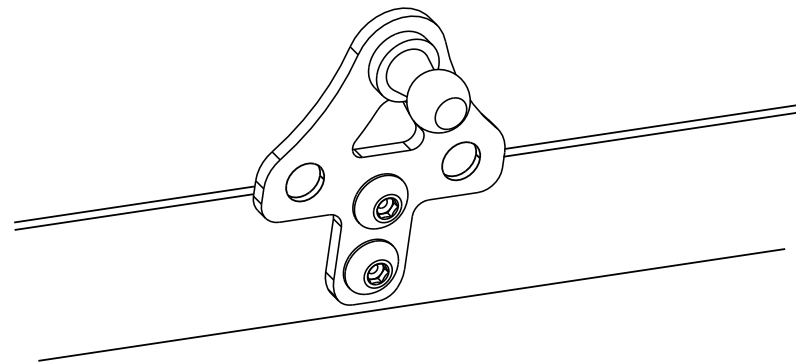

## Preparing the Panel Assembly, continued

SEE VIDEO #9 FOR THIS STEP



Insert rubber bumpers into the top of the panels. There are two holes in every other panel. It works best to twist the bumpers during installation, being sure that the tip mushrooms out completely on the underside.

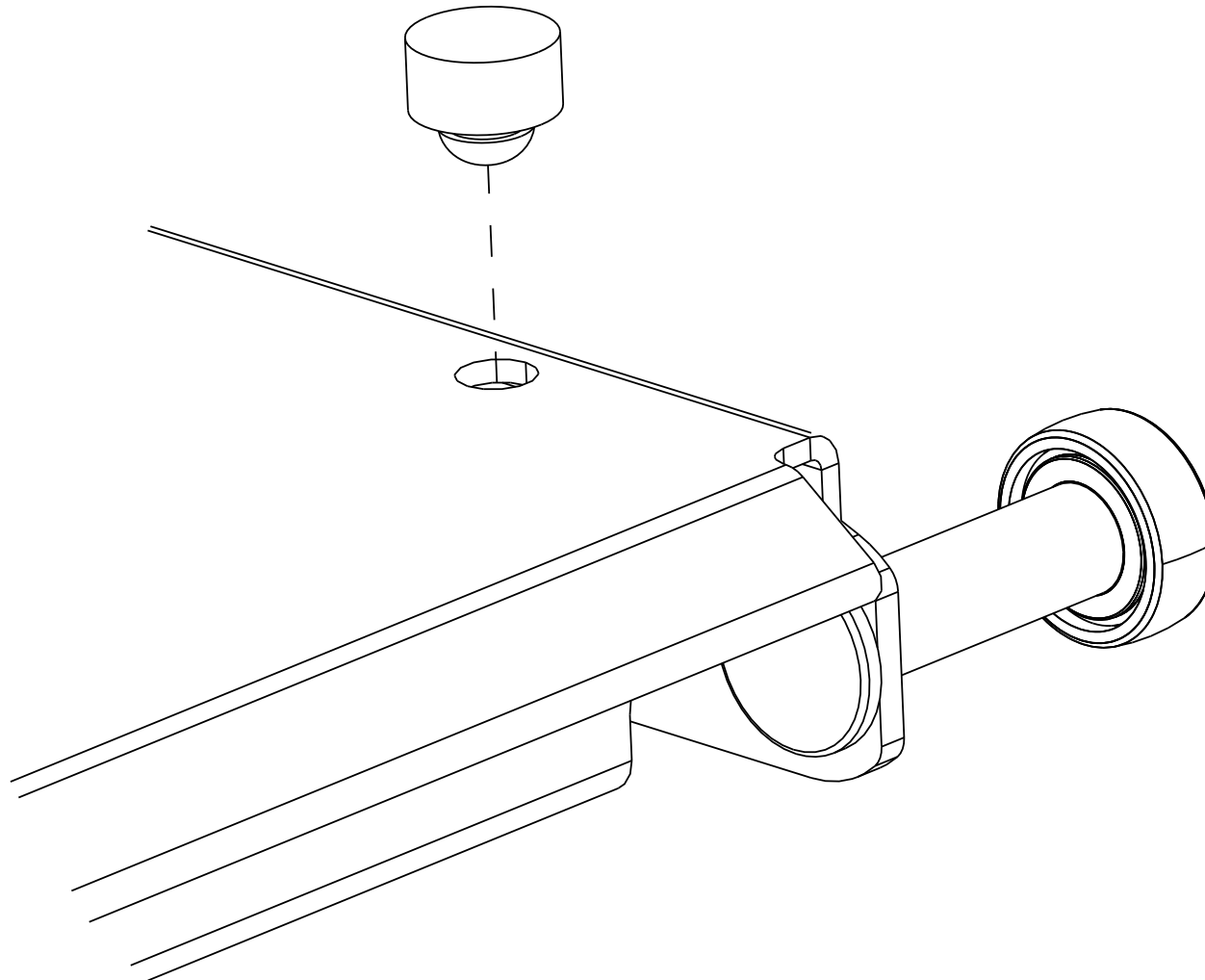

Note: If the bumpers are not staying in place, you may find that your rails are not parallel on the inside edge. Review the section on “Installing the Rails”

# Installing the Panel Assembly

SEE VIDEO #9 FOR THIS STEP

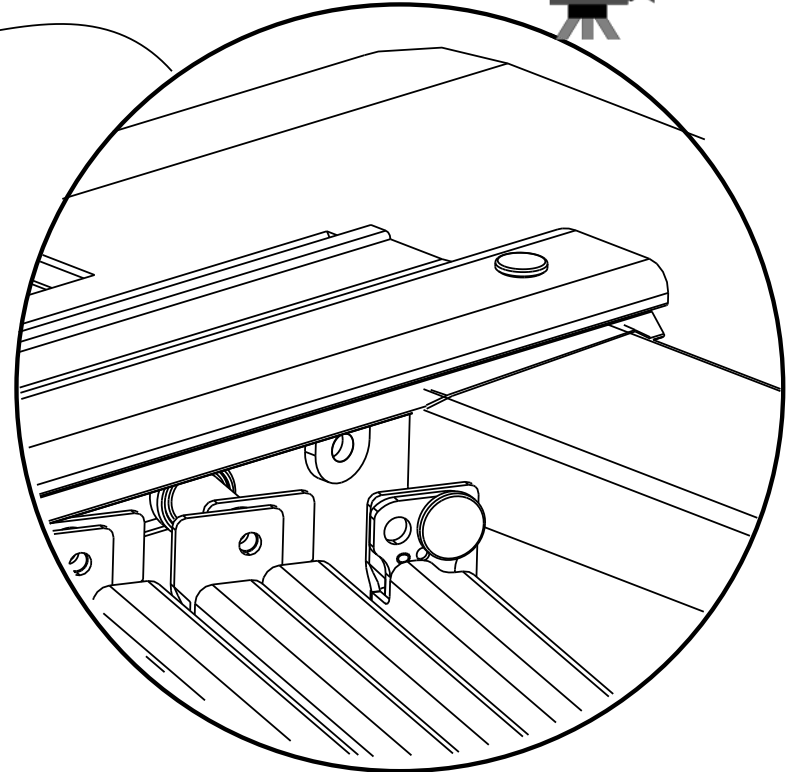
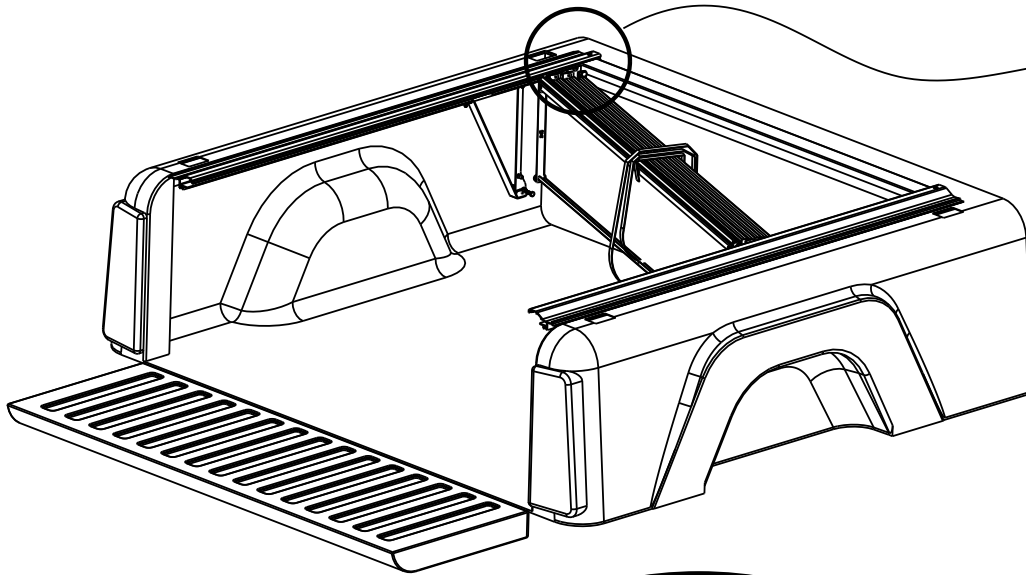

1) Wrap the pull strap around the folded cover. It makes the cover easier to carry.

2) Swing the folded cover into the driver side rail.

3) Insert pin on the first cover panel into corner bracket as shown in cutaway view.

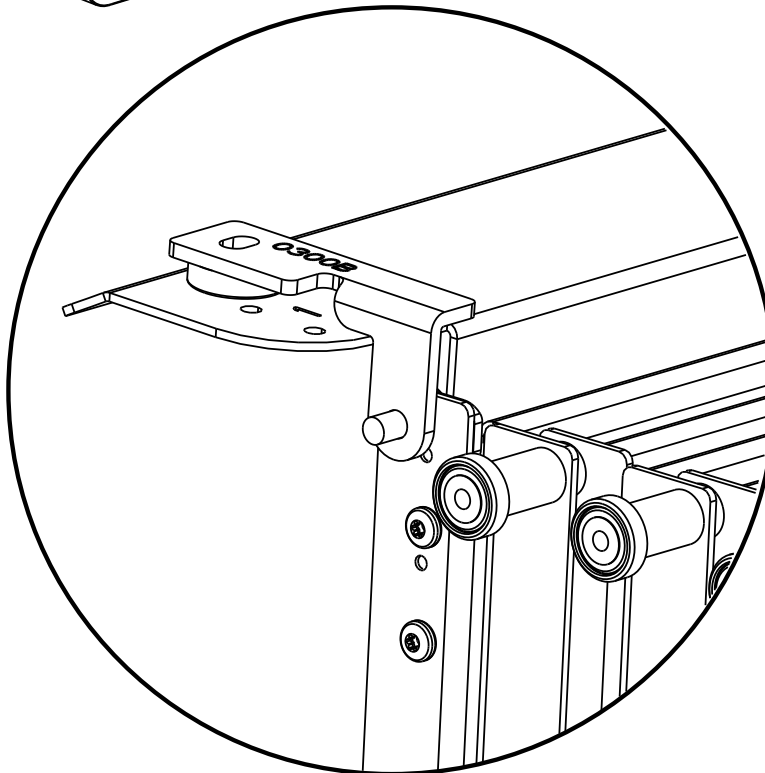

# Installing the Panel Assembly, continued

SEE VIDEO #9 FOR THIS STEP

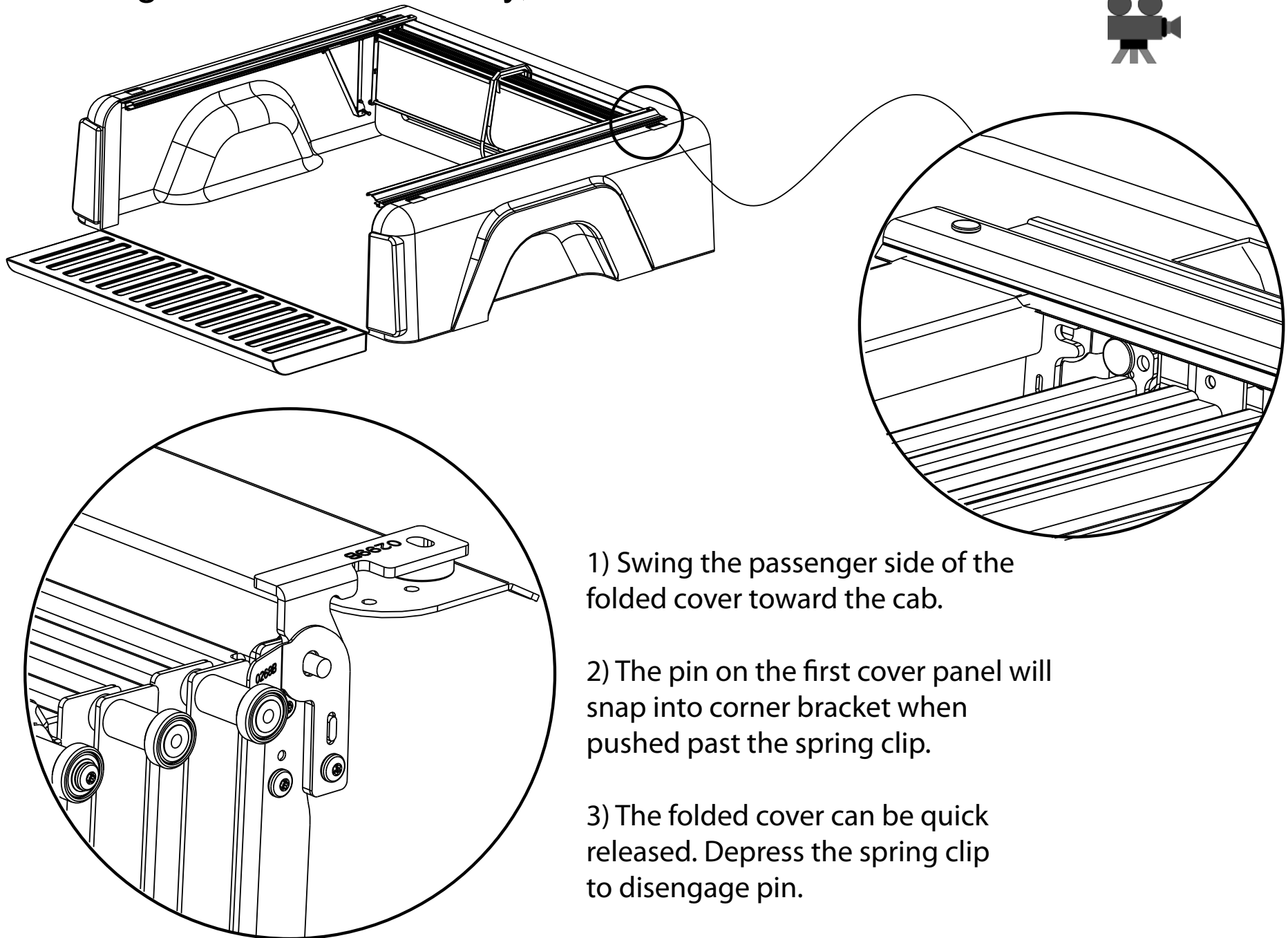

- 1) Swing the passenger side of the folded cover toward the cab.
- 2) The pin on the first cover panel will snap into corner bracket when pushed past the spring clip.
- 3) The folded cover can be quick released. Depress the spring clip to disengage pin.

# Initial ramp adjustment

SEE VIDEO #10 FOR THIS STEP



Assemble 4" bolt, nut and rubber cap into ramp as shown.

Turn bolt until cap touches bed and ramp is approximately 90 degrees to frame.

Watch video #10, then adjust as needed to ensure rollers ride up the ramp without falling off and that panels don't scrape on the inside edge of the ramp.

Feel free to put the jam nut on either side of the ramp if you prefer. Once final adjustments are made, you may replace the bolt with a shorter one for a more custom fit.

The bolt/nut will be tightened in a later step.

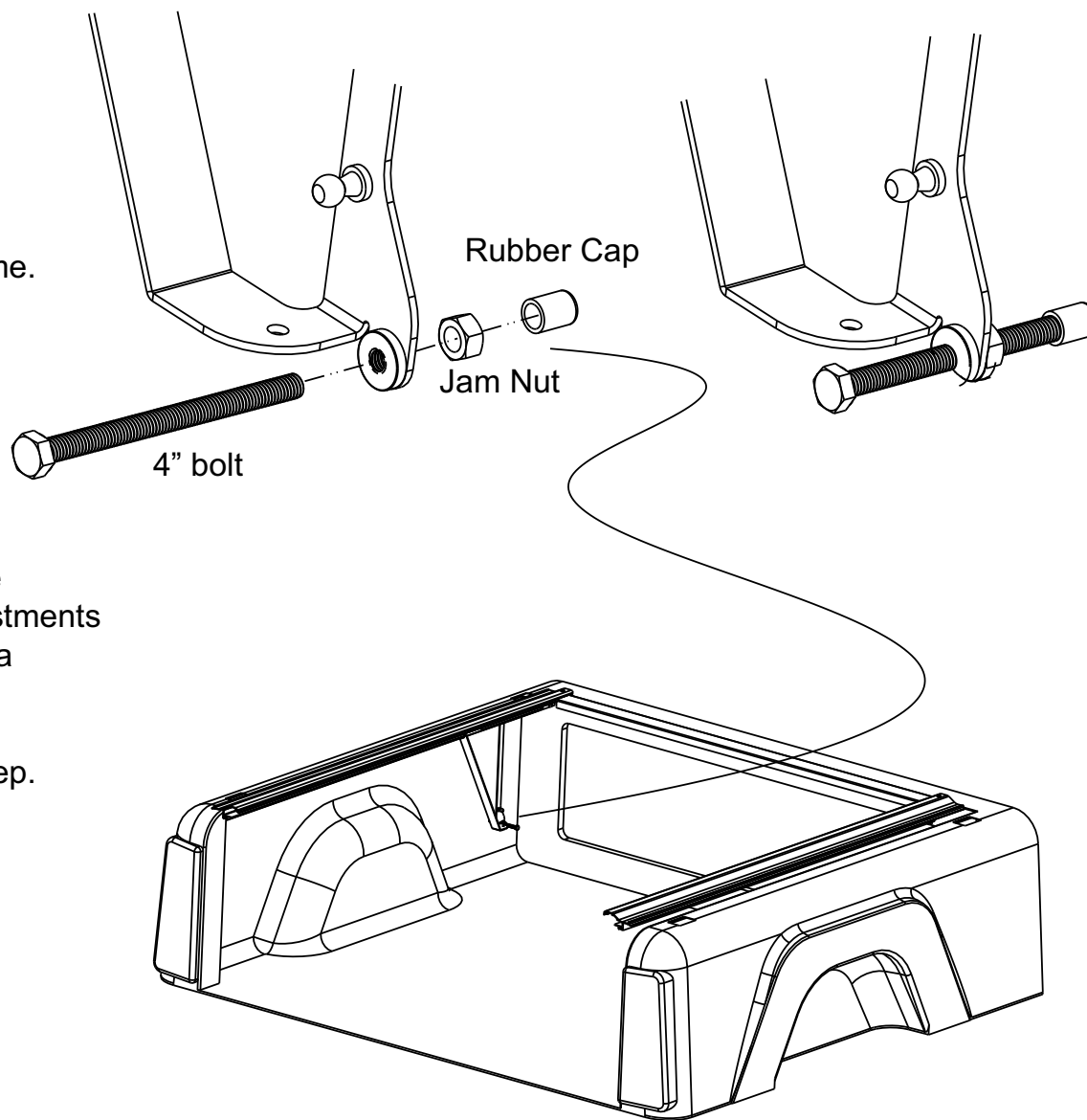

# Panel and frame adjustment

SEE VIDEO #11 FOR THIS STEP

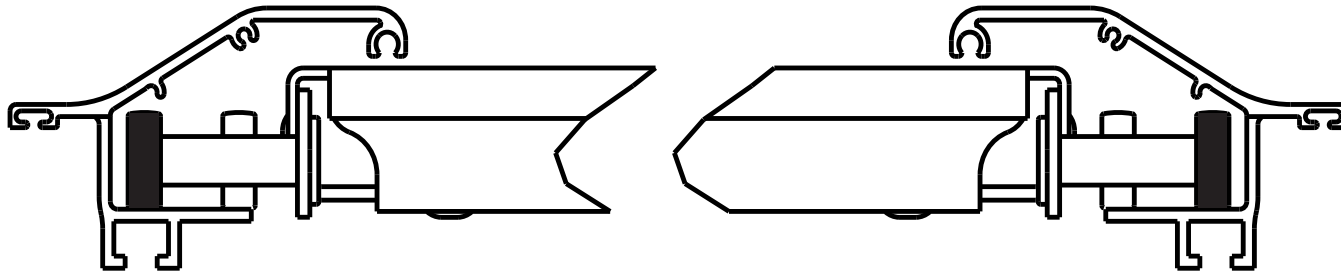

Slowly pull the cover closed with the tether strap and bring the rails together at the tailgate until both rails contact the bearings on the last panel.....

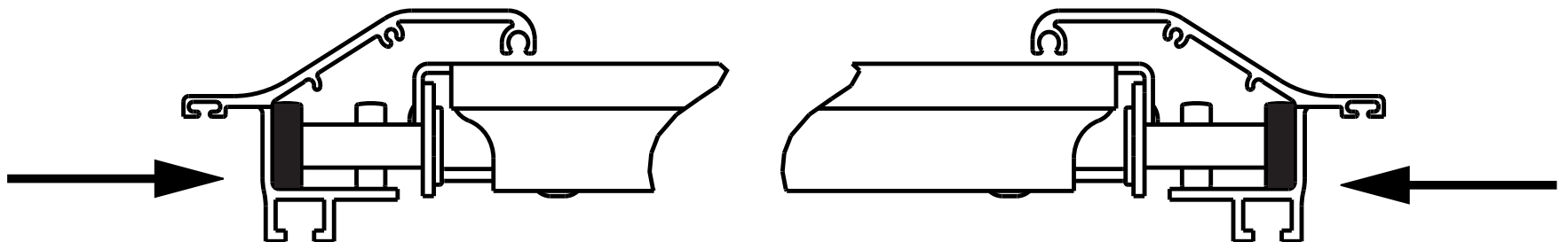

# Panel and Frame Adjustment, continued

SEE VIDEO #11 FOR THIS STEP



A. Entire length of rails requires a 3/16" gap between the truck and the bottom of the rails as shown at 'A'. How: See 'B'. If you have an 8' bed be careful that the center mounting point does not cause a bow in the rail.

B. Use the supplied spacers and/or spacing washers to achieve a square and properly spaced rail as shown at 'B'.

C. As with the cab end, center the rails at the tailgate, side-to-side, on the truck bed. When centered at tailgate, distance 'C' should be the same on the passenger and driver side.

D. When the rail spacing is correct at the tailgate, tighten the nuts until they are snug. Do NOT overtighten!!

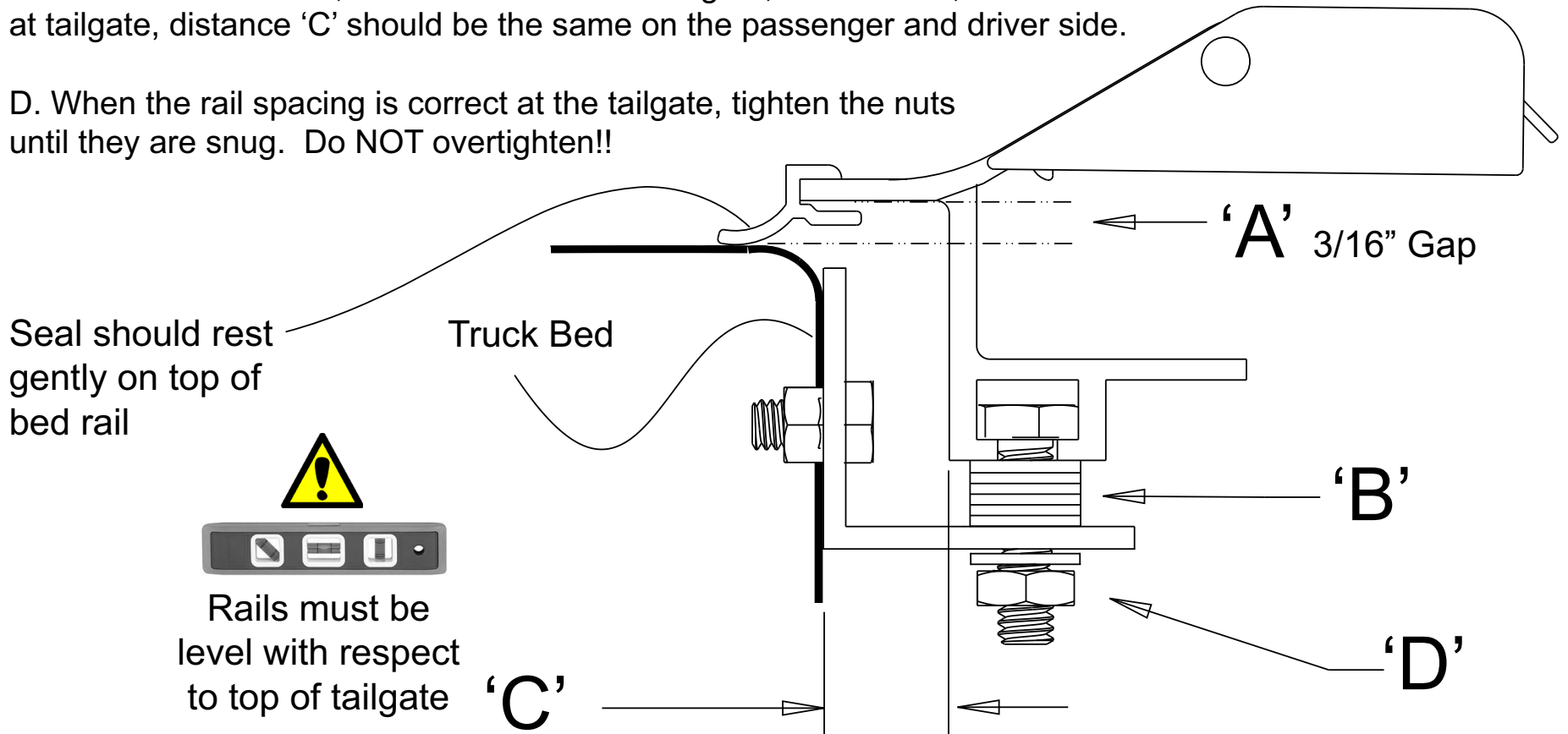

**The bracket orientation or seal design in this drawing depicts a typical installation, and may differ from yours**



## Testing The Operation

It's time for a check point.

Before attaching the gas springs, it's important to see if the cover is operating well in the rail system. You want to be sure there is no metal on metal binding. Pull on the nylon strap and see if the cover extends properly. **Note:** The cover will not extend completely flat until the gas springs are connected. If everything is installed correctly, the cover should move smoothly. If there is binding or if the cover is catching on something, you need to go back and check your work, particularly the rail alignment. Keep in mind that the rubber seals cause some resistance for the first week or so. These seals may make the cover more difficult to move at first.

After the cover is broken in, it should operate smoothly, with no binding. It may require a slight push to overcome the friction created by the seals.

If it does not operate well, follow the troubleshooting steps found here: <http://peragon.com/files/cover.pdf>

If your cover still does not operate well, double check that your rails are level (see diagram on the previous page) and the frame is the correct width. Double check the adjustment on your ramp assemblies as well.

**Fold the cover back up. If you're satisfied, then you can go to the next page and install the gas springs. Be sure the shaft of the spring points down.**

After you connect the gas springs, note the following.

**As the third and fourth panels begin to flatten out, the cover will become noticeably more difficult to pull. This happens because the gas springs are compressing. This is NORMAL.**

# Final Ramp Adjustment & Gas Spring Installation

SEE VIDEO #12 FOR THIS STEP

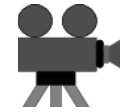

**HINT: Compress the spring several times prior to attachment. Attach the lower end (shaft end) first.**

Snap gas springs onto cover and ramp ball studs

Fat section attaches to cover



Gas Springs must be installed shaft end down or early failure will result!! Why? The internal seal dries out from lack of lubrication.

Tighten ramp nuts once cover is operating smoothly

The gas springs do not require tools to remove. Simply move the silver lever to the center position and pull the spring off the ball stud.

# Completing the Installation

SEE VIDEO #13 FOR THIS STEP



Cut tabs to separate end caps →

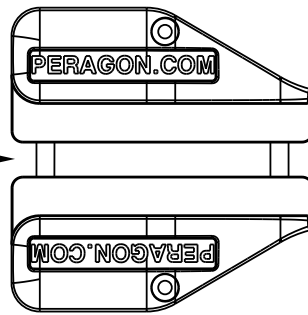

As with the ends caps installed on the cab end, now install the end caps on the tailgate side.

A dab of super glue on the edges of the end cap will help hold end caps in place. Watch to make sure you don't get glue on the rail surface!

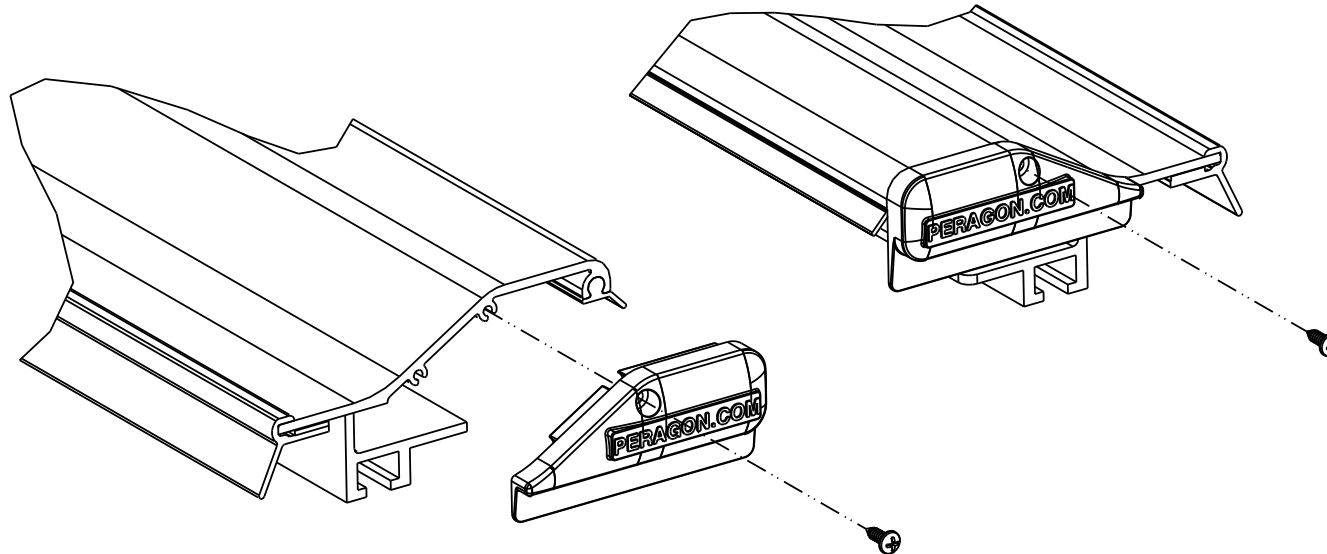

**To avoid damage, do not use a power screwdriver**

# NOTICE!!!!

WHEN THE COVER IS NEW, THE SEALS BETWEEN THE PANELS CAN BE STIFF, WHICH MAY RESULT IN A SAG AT THE FIRST HINGE. IF THIS HAPPENS, WE RECOMMEND LOCKING THE COVER WHILE IT IS PUSHED UP AND FLAT FROM UNDERNEATH. LEAVE IT LOCKED FOR 24-48 HOURS TO ALLOW THE SEALS TIME TO COMPRESS AND THE SAG SHOULD GO AWAY.

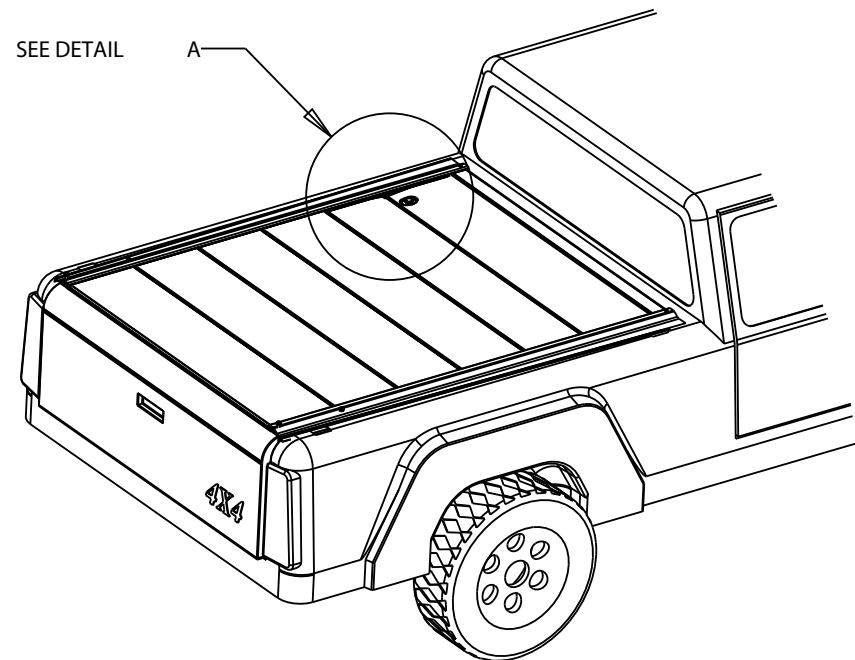
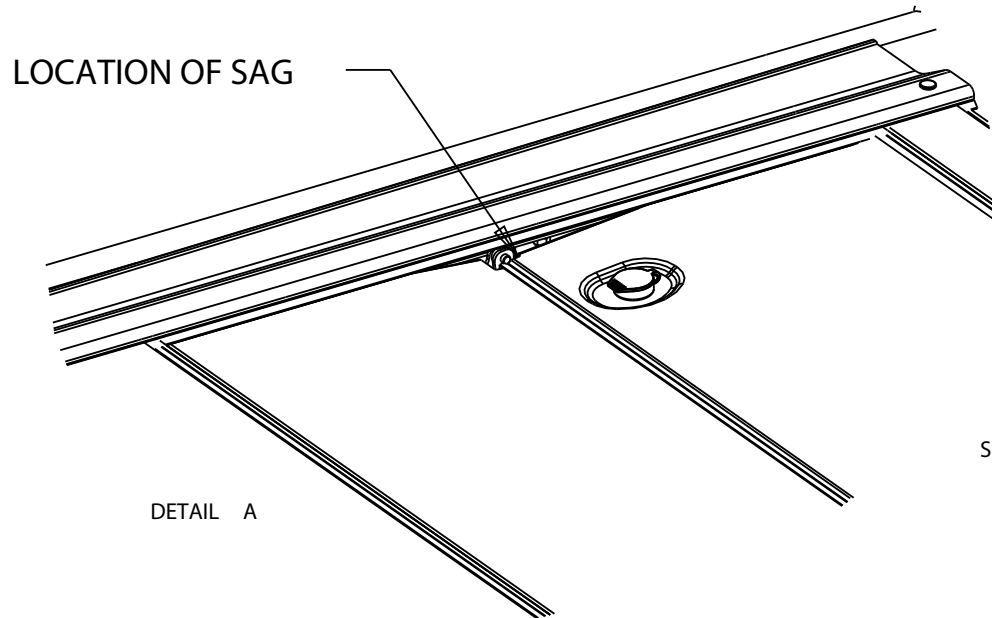

## Close and Open Cover

Unwind the pull strap and pull the cover closed. The bottom bearings will ride up the ramps into the rails. Locking the cover is optional because the gas springs will hold the cover closed. To open the cover, push down on the first and second panels behind the cab. You may find it necessary and helpful to grasp the last panel with your hand and guide the cover into the folded position.

- At first, the operation will be tight while the various parts break in.
- Maintenance suggestions: <https://www.dropbox.com/s/k6zgpdtamz3anl/CoverMaintenance.pdf?dl=0>
- If the operation is too stiff, follow the troubleshooting instructions at: <https://www.dropbox.com/s/kjuwwyj1egso078/Troubleshooting%20Installation%20Guide.pdf?dl=0>

***NOTE:** The gas springs may not push the first two panels up all the way until the seals have been compressed for a while. At first, the seal pressure may also cause the panels to be slightly uneven when closing.*

***NOTE:** A car wash dryer may push an unlocked cover open. Lock cover before a car wash.*

***NOTE:** A snow load bouncing on the cover can cause damage. Brush off snow before driving.*

## Traveling With the Cover Open

To travel with the cover secured in the open position, simply loop the pull strap around the folded panels and tie off. Rubber bumpers help protect the finished panel surfaces. However, care is still required. Do NOT tie the panels too tightly together and don't allow your cargo to rest against the folded panels. Pressure can cause the finished panel surfaces to rub in the center, damaging the finish. The loose end of pull strap MUST be secured when driving.

## Cover Quick Release

1. Fold the cover open.
2. Remove the gas springs by flipping the silver lever on the end fittings to the center position and pulling the spring off the ball stud.
3. Depress the quick release spring clip on the passenger side front corner to detach the cover from the frame. Swing the passenger side of the folded cover toward the tailgate until driver side also swings out of the rails.

## Warranty

### **One Year Limited Warranty Peragon Enterprises, Inc.**

This limited warranty is extended by Peragon Enterprises, Inc. to the original purchaser of a Peragon cover.

Peragon Enterprises, Inc. warrants its product to be free from manufacturer's defects for a period of one year from the date of purchase or 18 months from the date of manufacture, whichever occurs first. During this period, Peragon Enterprises, Inc., through its authorized dealer, will repair or replace, at its sole discretion, any part found to be defective as a result of the manufacturing process. (See how to make a claim.)

PERAGON ENTERPRISES, INC. DOES NOT WARRANT AGAINST DEFECTS RESULTING FROM IMPROPER INSTALLATIONS, MISUSE, ABUSE, ACCIDENTS, PRODUCT MODIFICATIONS, ACTS OF GOD, NEGLIGENCE OR DETERIORATION OF THE FINISH DUE TO IMPROPER MAINTENANCE OR EXPOSURE TO CHEMICALS AND/OR OTHER ENVIRONMENTAL CONDITIONS INCLUDING, BUT NOT LIMITED TO, WIND, HAIL, STORM, TORNADO, SUNLIGHT, ICE OR WATER. THIS WARRANTY DOES NOT EXTEND IN ANY RESPECT TO ACCESSORIES OR PARTS NOT PRODUCED BY PERAGON ENTERPRISES, INC. AND SHALL NOT EXTEND TO ANY CONSEQUENTIAL OR INCIDENTAL DAMAGES. THIS WARRANTY IS EXPRESSLY IN LIEU OF OTHER WARRANTIES EXPRESSED OR IMPLIED, INCLUDING THE WARRANTIES OF MERCHANTABILITY AND FITNESS FOR A PARTICULAR PURPOSE AND OF ALL OTHER OBLIGATIONS OR LIABILITIES ON THE PART OF PERAGON ENTERPRISES, INC. PERAGON ENTERPRISES, INC. NEITHER ASSUMES NOR AUTHORIZES ANY OTHER PERSON TO ASSUME FOR IT ANY OTHER LIABILITY IN CONNECTION WITH THE SALE OF ITS PRODUCT.

SOME STATES DO NOT ALLOW THE EXCLUSION OR LIMITATION OF INCIDENTAL OR CONSEQUENTIAL DAMAGES, OR LIMITS ON IMPLIED WARRANTIES. THEREFORE, THE ABOVE LIMITATIONS MAY NOT APPLY TO YOU. THIS WARRANTY GIVES YOU SPECIFIC LEGAL RIGHTS AND YOU MAY ALSO HAVE OTHER RIGHTS WHICH VARY FROM STATE TO STATE.

#### How to Make a Claim

To make a claim under this warranty, you must notify the dealer from whom the product was purchased of the defect or malfunction. (You may call Peragon Enterprises, Inc. if you require any assistance.) The dealer will examine the product and contact Peragon Enterprises, Inc. to determine if the claim is covered by the warranty. If determined by Peragon Enterprises, Inc. to be covered by its warranty, Peragon Enterprises, Inc. will send, at no cost to the warranty holder (including shipping costs within the continental U.S.A.), the replacement part or parts necessary to correct the defect. This warranty coverage is limited to parts only. If you have purchased your Peragon cover by mail order or any other outlet which excluded the service of installation and performed the installation on a do-it-yourself basis, your warranty coverage will be limited to parts only. To make a claim as a do-it-yourself installer you may, at Peragon's option, be required to return the defective parts, properly packaged and at your expense to Peragon Enterprises, Inc. warranty department. Contact Peragon for return shipping instructions. (Please include product serial number and a brief description of the problem). If the part or parts are found to be defective, the replacement part or parts will be returned to you at our expense (limited to the U.S.A. lower 48 states).

Peragon Enterprises, Inc. makes every effort to respond to every warranty claim in a timely fashion. However, availability of parts or labor will affect how long it takes to process your claim. If for whatever reason your claim cannot be processed immediately, you will be notified and given an approximate date for completion.

## Thank You!

Dear Customer -

Congratulations on your purchase of a Peragon cover! This product has been engineered to provide you with years of reliable use and convenience. While we have made every effort to insure that your ownership experience will be trouble-free, we encourage you to let us know if you experience any difficulty. Your satisfaction is our priority, and your feedback allows us to improve our products and service.

As an owner of a Peragon cover you have become part of a dream that began when we sat down with a blank sheet of paper and started to sketch out a design for what is now the best truck bed cover available. Bringing Peragon from a dream to reality has been a challenge, but we haven't worked alone.

From the very beginning, we have been determined to make God our Senior Partner. In a crisis, the problem is turned over to Him, and He has never failed to help us with the answer. Each bed cover that we produce must reflect the integrity of management, including our Senior Partner. If sometimes we fail because we are human, we find it imperative to do our utmost to make it right. In addition to being Senior Partner, He is also our Heavenly Father and it is a great blessing to us to have this security in these troubled times. If you are troubled or perplexed and looking for answers, may we invite you to look to Him, for God loves you. "For God so loved the world, that He gave His only begotten Son, that whosoever believeth in Him should not perish, but have everlasting life." – John 3:16

We take great pride in every Peragon cover that leaves our plant. Thank you for being a part of our dream!

Sincerely,

The Peragon Team